

THE SAI JOURNAL

ON LINE

Year 1, Issue 1

May 2004

BRACING NEWS

SAI motori idraulici celebrates 40th anniversary.



Widening diffusion of dual displacement motors.



SAI s.p.a. MOTORI IDRAULICI CELEBRATES ITS 40TH ANNIVERSARY

The SAI group has grown considerably from its beginnings in 1964 to a worldwide network involving many people of different companies and different countries. In the early 1970s the first company abroad was incorporated and nowadays many subsidiaries and manufacturing sites as well as international co-operations are established. Keeping track of all SAI activities is no easy task, and there is now a real need for all interested parties to receive regular information on new products, applications, exhibitions and other significant events. In recent years, during marketing seminars or various visits, many of you expressed strong support for a regular newsletter and noted a

need to increase the communication among the worldwide network especially on experiences arising from new applications and other sales activities. Now that the necessary resources are available, at least two issues will be produced yearly. Among the readers of this the first SAI newsletter will be those who already have a very good idea of the current SAI program and those who are not quite sure what SAI capabilities are. Thus the newsletter attempts to talk to the

regular SAI users and to supply a range of information for those who have little contact with the SAI world – a difficult compromise. Only through feedback from readers we will know if that objective has been achieved.

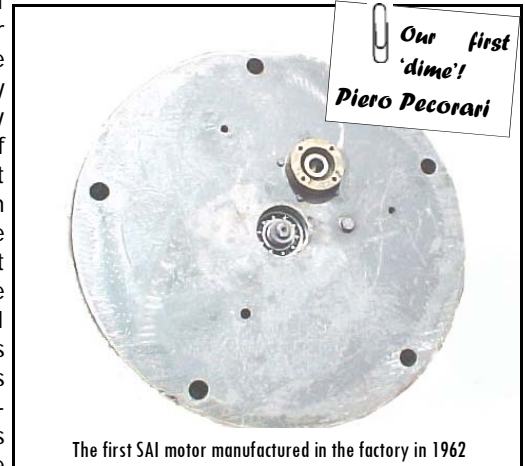

The first SAI motor manufactured in the factory in 1962

Summary:

After the 2004' Bauma	Page 2
Events of next season	Page 2
SAI (GB) Ltd now trading from Basildon Essex	Page 2
Dual Displacement drive units	Page 3
Wheel drive of a three wheeled loaded	Page 4

WHAT YOU WILL FIND INSIDE THIS NEWSLETTER

This newsletter contains sections dedicated to various topics. The two inside pages carry detail of SAI news, individual Company activities and latest product developments. You will find

information about forthcoming events at which SAI will be exhibiting as well as news coming from other SAI companies or partners worldwide. On page 3 is technical news of the latest

developments of our motors and drive units. On the final page is an area dedicated to interesting and innovative applications. We look forward to receiving interesting material from

the entire SAI sales network for future publication.





Earth moving machine equipped with SAI High Speed High Torque dual displacement motors.

AFTER THE 2004 'BAUMA'S

This year's 'Bauma' has given positive results to SAI with regard to quality of visitors, their evident expertise and their decision-taking competence. Mainly due to new innovations displayed, SAI has significantly increased the number of enquiries received. Most of the enquiries refer to double displacement motors, which are now receiving

positive interest from the market, both in Europe and abroad. The event was also very positive for the accessories (brakes and gearboxes division), with special interest for hydraulic driven axles (as already introduced at Industrie Messe in Hannover 2003) and track drives (SAI has displayed a rubber track sample in cooperation with a track manufacturer). A lot of

interest has also been generated by the high power motors, mainly for special application such as pumps and drilling heads.



Variable Displacement Motor Test bench.

EVENTS OF NEXT SEASON

The SAI Group participates in various international exhibitions every year. These events provide us with an excellent platform to present the SAI extensive product portfolio, and our skilled sales and after sales organisation. To the right you will find information of where the SAI Group companies will be exhibiting; where our personnel will be available for your further enquiries.

SAI Events 2004		
September 9-12	BAUCOM 2004 -Construction, Machinery and Building materials-	New Delhi, India
September 26-02	SMM -Shipbuilding - Machinery & Marine Technology Stand 03.06. 431	Hamburg, Germany
September 28-30	Motion & Control 2004 Hall 4 stand 550	Birmingham, UK
October 12-15	PTC ASIA Hall 4	Shanghai, China
November 10-14	EIMA & EIMA Garden	Bologna, Italy
November 16-19	BAUMA China	Shanghai, China



shipbuilding · machinery & marine technology

international trade fair hamburg

sept. 28 - oct. 2, 2004

www.smm2004.com



Contact person: Sandra Leporati at sandra@saispa.it

SAI (GB) LIMITED NOW TRADING FROM BASILDON ESSEX



The long planned move from Park Farm Buildings in Chelmsford to a brand new Factory Unit with plush, purpose built, Offices in Basildon was completed on 1st March 2004. The new location, should improve the Distribution of the SAI products offering a

better service to Customers. The increased area of the new Unit will allow for more Standard Motors and Components to be held in stock for immediate delivery.

Any existing or potential Customers are invited to drop in and see the new premises.

New address is:

SAI (GB) Limited, Unit 8, Honywood Road Business Park, Basildon SS14 3HW UK.

Telephone +44 (0)1268 272030 and FAX +44 (0) 1268 272040



Contact person: Kevin Parslow at info@saigb.co.uk



SAI (GB) new premises in Basildon welcome customers and potential customers.



SAI HYDRAULICS INC.
3905 W.9th St.
Trainer PA 19061 USA

Ph +16104970190
E-mail info@saihyd.com



SAI HYDR.CANADA LTD
6105 Blvd. Couture St
Leonard

Quebec CANADA
Ph +1514970194
Fax +15143234552



SAI BRASIL LTDA
Rua General Camara 229
Jardim California Piracicaba San Paulo BRASIL

E-mail Saibr@terra.com.br
Ph +551934262929



SAI (GB) LTD
Unit 8, Honywood Road
Business Park,

Basildon SS14 3HW UK
E-mail info@saigb.co.uk
Ph +441268 272030

DUAL DISPLACEMENT DRIVE UNITS

BD2 +WR20

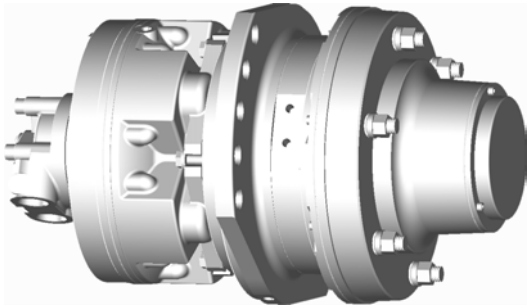

Well proven concept, high quality, high performance. Very precise and extremely reliable this product can operate in most extreme applications from wheel-drives in construction, forestry, to winch in material handling crane, deck machinery, capstan.

Description: Dual Displacement from 3300 to 600 cc /rev. High radial load capacity; with negative brake

Model Code: BD2 +WR20
Overall size: 140 Kg. Ø425
Data Sheet: 040402.1P

BD2+R24

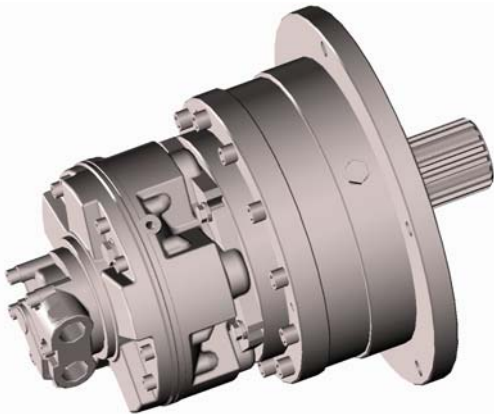

Newly developed, compact two speed drive unit. Very precise but extremely reliable this product can operate in heavy duty applications: anchor winch, winch material handling crane, deck machinery, hatch cover. High radial load capacity.

Description: Dual Displacement from 3000 to 550 cc/ rev.

Model Code: BD2 +R24
Overall size: 200 Kg. Ø459
Data Sheet: 040401.1P

BD5



Newly developed, dual displacement. Very flexible but extremely reliable this product can operate in every kind of high power applications: marine and industrial.

Can be coupled to all kind of gearboxes

Description: Dual Displacement from 1900 cc to 500 cc.

Model Code: BD5
Overall size: 170Kg. Ø495
Data Sheet: 040404.1P

 Request for technical information to luciano@saispa.it

 SAI OD
Odessa 27005 Ivanova
Str. 23 Ukraina
Ph +380482251361
E-mail info@eurocom.od.ua

 SAI INDIA Ltd.
26/C, Doddanekkundi
Ind.Area Phase 1 Post
Mahadevpura Bangalore 560048
India Ph +91808524434
E-mail hydromotor@vsnl.com

 SAI CHINA
1102-B North Bldg. 37
Suicheng S. Rd. Shangai
PRC
Ph +862162783734
E-mail saichina@saichina.net

 SAI JAPAN
3-2 Yotsuya, Shiniyuku
ku Tokyo 160-0004
Japan Ph +8133260851
E-mail sai@climb-1.co.jp



BD2+WR20 



BD2 two displacements hydr. Motor plus WR20 6.6x1

Displacement (cc)	1000	1600	800	2500	1100	600	600
Max. torque (Nm)	2300	1500	1500	2300	1500	1500	2300
Max. torque (kgm)	230	150	150	230	150	150	230
Max. torque (lbf.ft)	169	110	110	169	110	110	169
Max. torque (kgf.cm)	23000	15000	15000	23000	15000	15000	23000
Max. torque (kgf.m)	230	150	150	230	150	150	230
Max. torque (kgf.cm)	23000	15000	15000	23000	15000	15000	23000
Max. torque (kgf.m)	230	150	150	230	150	150	230
Max. torque (kgf.cm)	23000	15000	15000	23000	15000	15000	23000
Max. torque (kgf.m)	230	150	150	230	150	150	230
Max. torque (kgf.cm)	23000	15000	15000	23000	15000	15000	23000
Max. torque (kgf.m)	230	150	150	230	150	150	230
Max. torque (kgf.cm)	23000	15000	15000	23000	15000	15000	23000
Max. torque (kgf.m)	230	150	150	230	150	150	230
Max. torque (kgf.cm)	23000	15000	15000	23000	15000	15000	23000
Max. torque (kgf.m)	230	150	150	230	150	150	230
Max. torque (kgf.cm)	23000	15000	15000	23000	15000	15000	23000
Max. torque (kgf.m)	230	150	150	230	150	150	230
Max. torque (kgf.cm)	23000	15000	15000	23000	15000	15000	23000
Max. torque (kgf.m)	230	150	150	230	150	150	230
Max. torque (kgf.cm)	23000	15000	15000	23000	15000	15000	23000
Max. torque (kgf.m)	230	150	150	230	150	150	230
Max. torque (kgf.cm)	23000	15000	15000	23000	15000	15000	23000
Max. torque (kgf.m)	230	150	150	230	150	150	230
Max. torque (kgf.cm)	23000	15000	15000	23000	15000	15000	23000
Max. torque (kgf.m)	230	150	150	230	150	150	230
Max. torque (kgf.cm)	23000	15000	15000	23000	15000	15000	23000
Max. torque (kgf.m)	230	150	150	230	150	150	230
Max. torque (kgf.cm)	23000	15000	15000	23000	15000	15000	23000
Max. torque (kgf.m)	230	150	150	230	150	150	230
Max. torque (kgf.cm)	23000	15000	15000	23000	15000	15000	23000
Max. torque (kgf.m)	230	150	150	230	150	150	230
Max. torque (kgf.cm)	23000	15000	15000	23000	15000	15000	23000
Max. torque (kgf.m)	230	150	150	230	150	150	230
Max. torque (kgf.cm)	23000	15000	15000	23000	15000	15000	23000
Max. torque (kgf.m)	230	150	150	230	150	150	230
Max. torque (kgf.cm)	23000	15000	15000	23000	15000	15000	23000
Max. torque (kgf.m)	230	150	150	230	150	150	230
Max. torque (kgf.cm)	23000	15000	15000	23000	15000	15000	23000
Max. torque (kgf.m)	230	150	150	230	150	150	230
Max. torque (kgf.cm)	23000	15000	15000	23000	15000	15000	23000
Max. torque (kgf.m)	230	150	150	230	150	150	230
Max. torque (kgf.cm)	23000	15000	15000	23000	15000	15000	23000
Max. torque (kgf.m)	230	150	150	230	150	150	230
Max. torque (kgf.cm)	23000	15000	15000	23000	15000	15000	23000
Max. torque (kgf.m)	230	150	150	230	150	150	230
Max. torque (kgf.cm)	23000	15000	15000	23000	15000	15000	23000
Max. torque (kgf.m)	230	150	150	230	150	150	230
Max. torque (kgf.cm)	23000	15000	15000	23000	15000	15000	23000
Max. torque (kgf.m)	230	150	150	230	150	150	230
Max. torque (kgf.cm)	23000	15000	15000	23000	15000	15000	23000
Max. torque (kgf.m)	230	150	150	230	150	150	230
Max. torque (kgf.cm)	23000	15000	15000	23000	15000	15000	23000
Max. torque (kgf.m)	230	150	150	230	150	150	230
Max. torque (kgf.cm)	23000	15000	15000	23000	15000	15000	23000
Max. torque (kgf.m)	230	150	150	230	150	150	230
Max. torque (kgf.cm)	23000	15000	15000	23000	15000	15000	23000
Max. torque (kgf.m)	230	150	150	230	150	150	230
Max. torque (kgf.cm)	23000	15000	15000	23000	15000	15000	23000
Max. torque (kgf.m)	230	150	150	230	150	150	230
Max. torque (kgf.cm)	23000	15000	15000	23000	15000	15000	23000
Max. torque (kgf.m)	230	150	150	230	150	150	230
Max. torque (kgf.cm)	23000	15000	15000	23000	15000	15000	23000
Max. torque (kgf.m)	230	150	150	230	150	150	230
Max. torque (kgf.cm)	23000	15000	15000	23000	15000	15000	23000
Max. torque (kgf.m)	230	150	150	230	150	150	230
Max. torque (kgf.cm)	23000	15000	15000	23000	15000	15000	23000
Max. torque (kgf.m)	230	150	150	230	150	150	230
Max. torque (kgf.cm)	23000	15000	15000	23000	15000	15000	23000
Max. torque (kgf.m)	230	150	150	230	150	150	230
Max. torque (kgf.cm)	23000	15000	15000	23000	15000	15000	23000
Max. torque (kgf.m)	230	150	150	230	150	150	230
Max. torque (kgf.cm)	23000	15000	15000	23000	15000	15000	23000
Max. torque (kgf.m)	230	150	150	230	150	150	230
Max. torque (kgf.cm)	23000	15000	15000	23000	15000	15000	23000
Max. torque (kgf.m)	230	150	150	230	150	150	230
Max. torque (kgf.cm)	23000	15000	15000	23000	15000	15000	23000
Max. torque (kgf.m)	230	150	150	230	150	150	230
Max. torque (kgf.cm)	23000	15000	15000	23000	15000	15000	23000
Max. torque (kgf.m)	230	150	150	230	150	150	230
Max. torque (kgf.cm)	23000	15000	15000	23000	15000	15000	23000
Max. torque (kgf.m)	230	150	150	230	150	150	230
Max. torque (kgf.cm)	23000	15000	15000	23000	15000	15000	23000
Max. torque (kgf.m)	230	150	150	230	150	150	230
Max. torque (kgf.cm)	23000	15000	15000	23000	15000	15000	23000
Max. torque (kgf.m)	230	150	150	230	150	150	230
Max. torque (kgf.cm)	23000	15000	15000	23000	15000	15000	23000
Max. torque (kgf.m)	230	150	150	230	150	150	230
Max. torque (kgf.cm)	23000	15000	15000	23000	15000	15000	23000
Max. torque (kgf.m)	230	150	150	230	150	150	230
Max. torque (kgf.cm)	23000	15000	15000	23000	15000	15000	23000
Max. torque (kgf.m)	230	150	150	230	150	150	230
Max. torque (kgf.cm)	23000	15000	15000	23000	15000	15000	23000
Max. torque (kgf.m)	230	150	150	230	150	150	230
Max. torque (kgf.cm)	23000	15000	15000	23000	15000	15000	23000
Max. torque (kgf.m)	230	150	150	230	150	150	230
Max. torque (kgf.cm)	23000	15000	15000	23000	15000	15000	23000
Max. torque (kgf.m)	230	150	150	230	150	150	230
Max. torque (kgf.cm)	23000	15000	15000	23000	15000	15000	23000
Max. torque (kgf.m)	230	150	150	230	150	150	230
Max. torque (kgf.cm)	23000	15000	15000	23000	15000	15000	23000
Max. torque (kgf.m)	230	150	150	230	150	150	230
Max. torque (kgf.cm)	23000	15000	15000	23000	15000	15000	23000
Max. torque (kgf.m)	230	150	150	230	150	150	230
Max. torque (kgf.cm)	23000	15000	15000	23000	15000	15000	23000
Max. torque (kgf.m)	230	150	150	230	150	150	230
Max. torque (kgf.cm)	23000	15000	15000	23000	15000	15000	23000
Max. torque (kgf.m)	230	150	150	230	150	150	230
Max. torque (kgf.cm)	23000	15000	15000	23000	15000	15000	23000
Max. torque (kgf.m)	230	150	150	230	150	150	230
Max. torque (kgf.cm)	23000	15000	15000	23000	15000	15000	23000
Max. torque (kgf.m)	230	150	150	230	150	150	230
Max. torque (kgf.cm)	23000	15000	15000	23000	15000	15000	23000
Max. torque (kgf.m)	230	150	150	230	150	150	230
Max. torque (kgf.cm)	23000	15000	15000	23000	15000	15000	23000
Max. torque (kgf.m)	230	150	150	230	150	150	230



SAI Spa Hydraulic Motors
Via Olanda 51
41100 Modena Italy
ph +39059420111
fax +39059451260
E-mail saispa@saispa.it

Editor: Vittorio Pecorari
Match opinions with the Editor :
E-mail vittorio@saispa.it

Look for more on our website:
www.saispa.com

Thanks to:

- Peter Waknell for -SAI (GB)- photo
- German Undurraga for -three wheeled loader- photo

THREE-WHEELED LOADER EQUIPPED WITH THE NEW BD2 MOTOR PLUS WR20 GEARBOX

SAI presents an application of the two-displacement motor offering incomparable performances



Designed particularly for use in mobile equipment, the new BD2 motor from SAI Hydraulic Motors provides optimum torque and speed output combined with the highest power



rate in its range. The BD2, the first of a high-speed high torque range of two-speed motors, matched with the well-proven WR20 wheel gearbox, is designed for use on application having up to 75 kW on each wheel.

High Torque High Speed

The BD2 500-125 (493 cc/rev in max. displ. and 121 cc/rev in min. displ.) at 350 bar provides all the torque expected of its heavy-duty radial piston design. In addition in minimum displacement it reaches a peak speed over 2000 rpm, more than twice the speed of the

standard GM motor series, offering fast shift when changing working site.

Smooth Speed Change

The shift between maximum and minimum speed can be done dynamically, both from min to max and reverse. The displacement in acceleration is continuous giving a smooth, jolt free shift. The greater degree of flexibility that this motor range can offer, matched with the typical SAI motor performances, offers high efficiency of the transmission and limited engine operational range close to the maximum efficiency condition. This means fuel economy, high shift quality providing smooth jolt-free starting on slopes. The BD2 two-speed motor is designed to provide the optimum torque-speed ratio providing high torque in the working range and high speed in the travel range.

Performances and Durability

The BD motors have undergone an extensive development program as part of the SAI vision of broad in-house testing at the R&D facility in Modena. Subsequent to that,

the prototype three-wheeled loader has been tested for several months as pilot application. Now the performances and the durability have been proven in the field with an extraordinary degree of success and the end-users have expressed great appreciation for the improved performances of the machine during its demonstration day. See SAI BD2+WR20 leaflet 040402.1P



Contact: Giovanni Pecorari –
S a l e s M a n a g e r
SAI S.p.A. Hydraulic Motors
Via Olanda, 51
41100 Modena
Italy
Tel. +39 059 420 247
Fax. +39 059 451 260
E-mail: giovanni@saispa.it